

**Putzmeister**

# Truck-mounted concrete pump

# BSF 20-4.09 H

Output up to 90 m<sup>3</sup>/h  
 Delivery pressure up to 78 bar\*

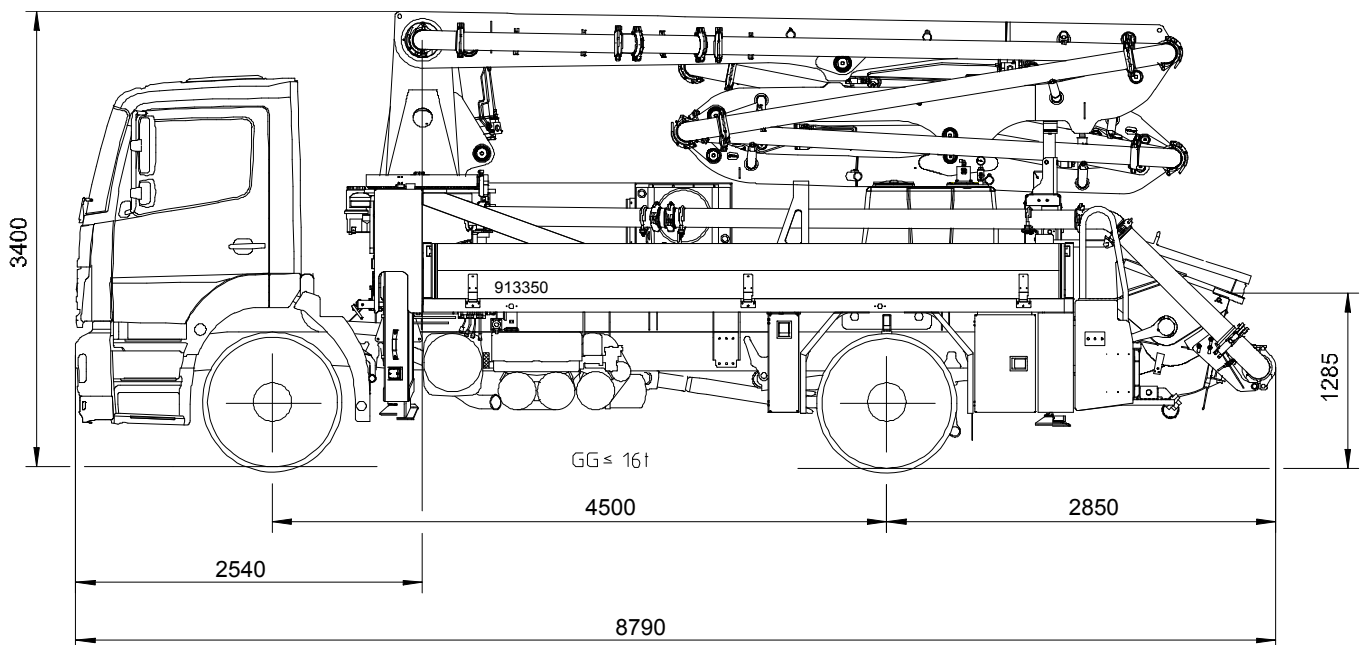
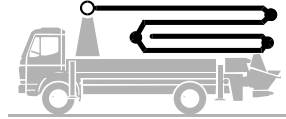

Note: Standard version. Dimensions and weights depend on truck and equipment.  
 Dimensions in mm, MB-Axor 1828 as example.  
 For illustration only.

## Technical data

Boom M 20-4			
Sections			4
Reach height	m		19.5
Horizontal reach	gross	m	16.1
	net	m	13.8
Reach depth max.	m		11.1
Unfolding height	m		3.9
End hose length	m		3
Folding system			ZR
Delivery line			DN 125

Pump		BSF	.09 H
Rod side	Output	m <sup>3</sup> /h	-
	Delivery pressure	bar	-
	Strokes	1/min.	-
Piston side	Output	m <sup>3</sup> /h	90
	Delivery pressure	bar	78
	Strokes	1/min.	26
	Delivery cylinder	Ø mm	230
	Stroke	mm	1400

All data maximum theoretical.

# Reach information diagram, Support, Performance diagram

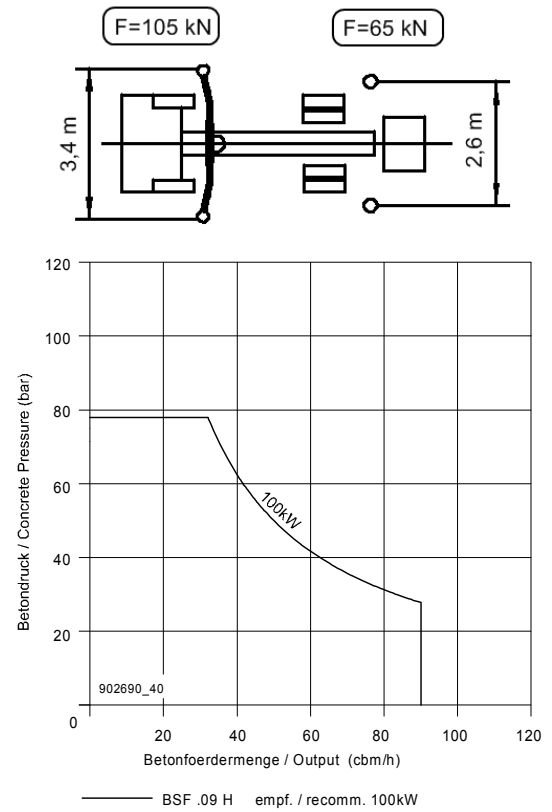
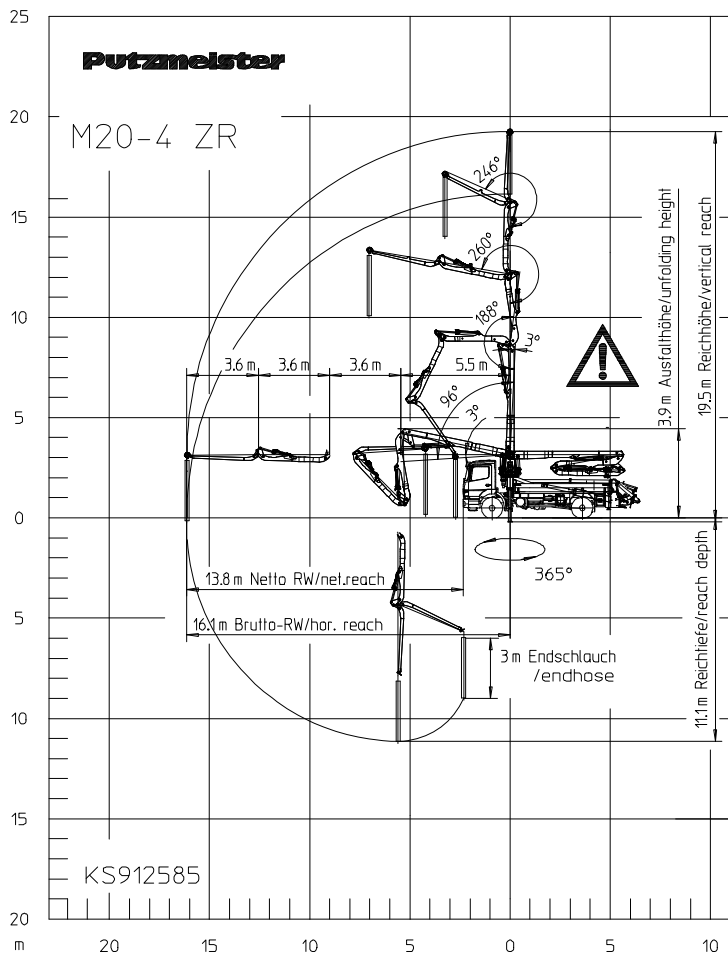

All data max. theor.

Range in which you must not work with the end hose.

Dimensions can differ depending on configuration.

## Serial delivery scope

Agitator and water pump radio remote/on site controlled	Flushing water pump 160 l/min 25 bar	S-transfer tube switchover fast/slow
Cardan shaft maintenance free	Hinged elbow with cleaning port	Support plates (4 x) in magazine (2 x) open
Central lubrication strip hopper	Hydraulic hose for replacement in hose pack	Tool set incl. standard equipment
Chassis horn via remote control on hopper	Operating manuals 2 x (1 x paper, 1 x CD-ROM) spare part list	Towing eye
Concrete hopper RS 600	Platform non-skid	Wash-out port lid with slide pin
Connections for hydraulic emergency supply	Pump on/off dependent on speed	Water supply, hopper (1/2")
C-pipe connection for filling water tank	Radio remote control proportional with display	Water tank 610 l
Delivery cylinder chrome-plated	Rear and brake light 24 V	Working light for illumination of hopper, detachable
Delivery line (1-layer) PM40, arm assembly	Remote control without display with 25 m cable	
Delivery piston 'compact'	RS 600 with S 2015D and slewable 90° elbow	
Diagnose interface	Rubber collar on concrete hopper	
End hose 3,0 m DN 125, 5,5"	Side panel left foldable	
Ergonic Graphic Display (EGD) with machine fault management	Side panel right foldable	
Ergonic Pump System (EPS) incl. Ergonic Output Control (EOC)	Spectacle wear plate DURO 22	
	Splash guard fixed	
	Spray hose 10 m incl. bracket	

See quotation for exact serial delivery scope.  
Comprehensive range of options available on request.