

Portable concrete pumps PCC607/411 D6

Description

A complete range, whether on small job sites, shotcrete pumping or big civil works.

In every situation, these pumps offer stability, low running costs and steady flow.

All pumps are provided with excellent standard supply, complete with a wide choice of accessories for versatility, making them ideal for every type of jobsite.

Dimensions and performance diagrams

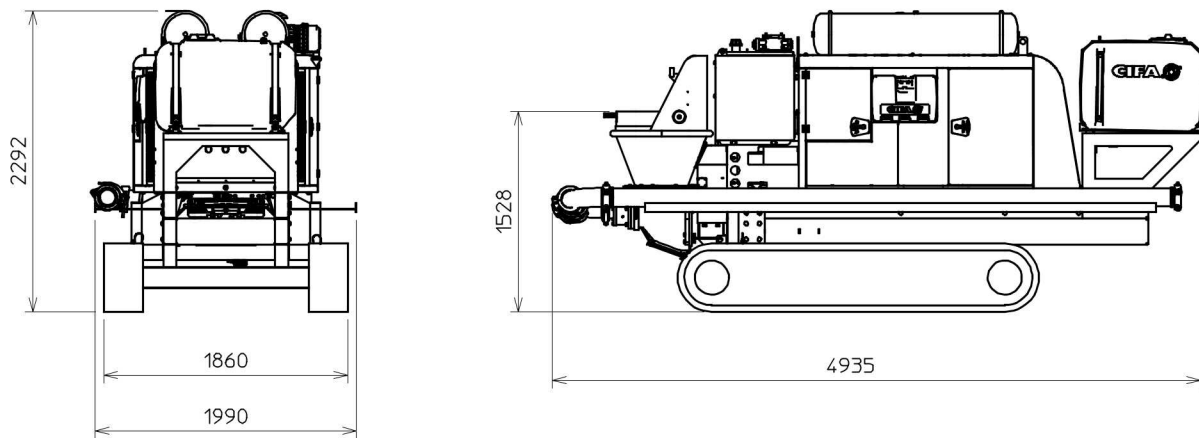

PC 607/411 D6

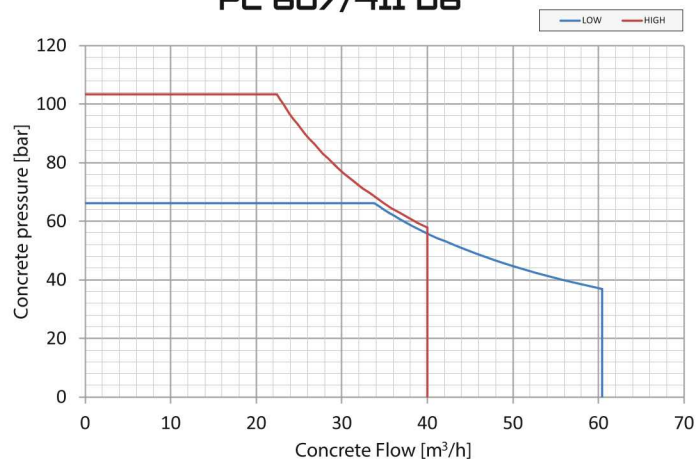

Portable concrete pumps

PCC607/411 D6

Main features

The Cifa portable concrete pump series offers a wide range of models which satisfy the various needs of concrete pumping and handling both in tunnels and above ground, over long distances and at considerable heights.

The Cifa original pumping unit presents characteristics of resistance, long life and exceptional performances with any type of concrete.

The main pump is an axial piston type with variable flow and constant power; gear pump is used for auxiliary services.

- S-valve for any type of concrete, made of special steel and different thicknesses
- Rapid valve exchange
- Ideal operation even at high pressures with continuous and smooth pumping flow
- Automatic wear compensation
- Hydraulic system in open circuit
- Low noise
- Low running costs
- Easy maintenance and quick cleaning operations
- Machines can work up to -25°

Standard equipment

- Perkins engine: Stage IIIA 83 kW
- Deutz engine: Stage V 85 kW
- Crawler mounted
- Radio remote control: traction, pumping unit management, lights, diesel engine, shut-off valve
- no. 4 led lights and flashing yellow lights
- Optical and acoustic warning devices
- External plastic water tank, capacity 600 liters
- No. 4 air tanks, made of stainless steel, total capacity 250 liters
- Concrete outlet piping with bend and counterbend reduction device up to 5"
- Plastic tool box
- Metal accessories storage bin
- Pressure sprayer
- Electric vibrator on the hopper grid
- Hydraulically driven water pump 50 l/min - 50 bar
- Concrete flow rate regulator on board
- Washing pipe complete with nozzle
- Connection flange for washing
- N° 2 sponge rubber balls
- Remote control with 20m cable
- Acoustic signal for diesel engine breakdown
- Two colours CIFA painting (orange and grey)
- Hydraulically controlled air compressor, bicilindrical, two-stage capacity 450 l/min intaken, max. pressure 15 bar, complete with accessories, stopballs cage and stub pipe

Optionals

- Stopballs cage and stub pipe diam. 5.5" with joint

Technical data

Model		PC 607	PC 411
Drive power IIIA	kW	83	83
Drive power Stage V	kW	85	85
Drive power E	kW	N/A	N/A
Max. theoretical output	m ³ /h	60	40
Max. pressure on concrete	bar	67	105
Max. number of cycles per minute		41	27
Concrete cylinders (diam. x stroke)	mm	176x1000	176x1000
Concrete hopper capacity	/	350	350
Rod side drive □ / Piston side drive ◆		□	◆

Technical data and characteristics subject to modifications without notice